

# MRB600

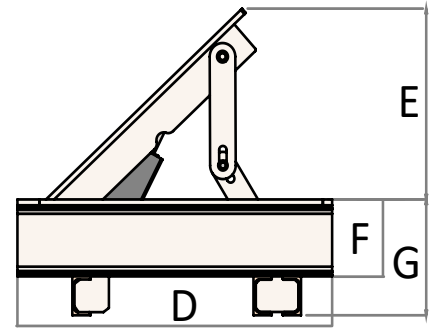
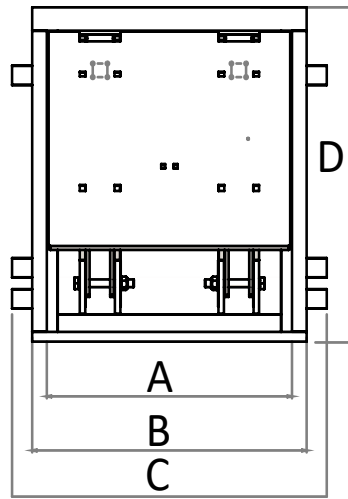

## AUTOMATIC MINI ROAD BLOCKER

- HYDRAULIC MOVEMENT
- HYDRAULIC PISTON INCLUDED
- ELECTRONIC CONTROL BOARD: OPTIONAL
- CUSTOM CONFIGURATION

U.M. = mm						
A	B	C	D	E	F	G
670	750	860	860	500	198	298

MRB600 H500		
MATERIAL OF MOVING PLATE		S335JRC
TREATMENT OF FORMWORK, STRUCTURE AND MOVING PART		HOT DIP GALVANIZATION
REFLECTIVE STRIP		•
BREAKOUT RESISTANCE	J	1.200.000
IMPACT RESISTANCE	J	250.000
STATIC RESISTANCE (CERTIFIED D400)	Kg	15.000
DAILY CYCLES INTENSIVE USE	N°	2.400
AVERAGE LIFE CYCLES WITHOUT MAINTENANCE	N°	1.500.000
MAXIMUM PRESSURE OF WORK	bar	30
POWER ABSORBED	W	550
POWER SUPPLY	Vac	220V 50 Hz
TEMPERATURE OF WORK	°C	-20 / + 80
ROHS REQUIREMENTS		•

• = standard equipment

MRB600 H500		0351202206	
HEIGHT FROM THE GROUND	mm		500
RAISING TIME	sec		2,5
LOWERING TIME	sec		1,5
WEIGHT	Kg		286