

C275G

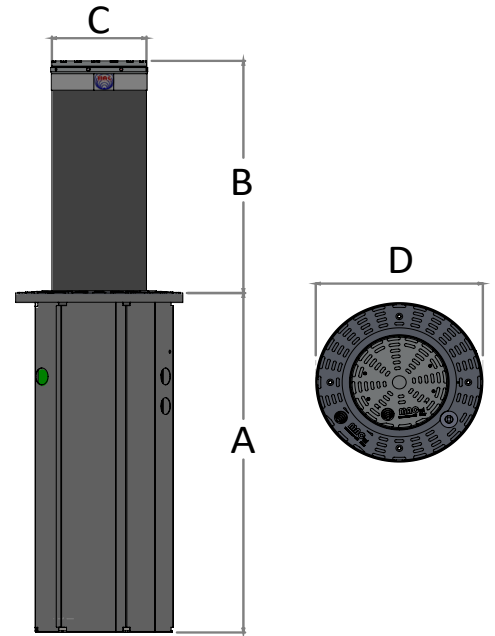

SEMI AUTOMATIC BOLLARD

- GAS SPRING MOVEMENT
- FORMWORK AND STRUCTURE HOT DIP GALVANIZED
- HEXAGONAL LOCK
- 200 mm BURIED TUBE
- CUSTOM CONFIGURATION



U.M. = mm			
A	B	C	D
731	500	275	484
931	700		
1031	800		

		C275G	C275G	C275G I
THICKNESS OF THE TUBE	mm	12,5	4	4
DIAMETER OF THE TUBE	mm	275		
MATERIAL OF THE TUBE		S335JRC	S235JRC	AISI304
TREATMENT AND FINISH OF THE TUBE		HOT DIP GALVANIZATION + POWDER PAINT		BRUSHED
TREATMENT FORMWORK AND STRUCTURE		HOT DIP GALVANIZATION		
REFLECTIVE STRIP		•		
RESISTANCE TO BREAKAGE	J	482.000	270.000	290.000
RESISTANCE TO DEFORMATION	J	60.000	30.000	50.000
STATIC RESISTANCE (CERTIFIED D400)	Kg	40.000		

• = standard equipment

C275G H500		033161212	033160402	033160452
WEIGHT	Kg	100	72	78
C275G H700		033161214	033160404	033160454
WEIGHT	Kg	140	94	74
C275G H800		033161214	033160405	033160455
WEIGHT	Kg	160	106	74