

C140G

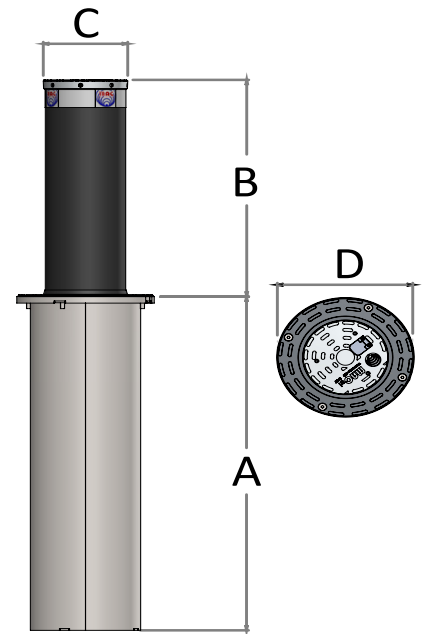

SEMI AUTOMATIC BOLLARD

- GAS SPRING MOVEMENT
- FORMWORK AND STRUCTURE HOT DIP GALVANIZED
- HEXAGONAL LOCK
- 200 mm BURIED TUBE
- CUSTOM CONFIGURATION



U.M. = mm			
A	B	C	D
749	500	140	278
949	700		

		C140G	C140G	C140G I
THICKNESS OF THE TUBE	mm	12,5	4	4
DIAMETER OF THE TUBE	mm	275		
MATERIAL OF THE TUBE		S335JRC	S235JRC	AISI304
TREATMENT AND FINISH OF THE TUBE		HOT DIP GALVANIZATION + POWDER PAINT		BRUSHED
TREATMENT FORMWORK AND STRUCTURE		HOT DIP GALVANIZATION		
REFLECTIVE STRIP		•		
RESISTANCE TO BREAKAGE	J	112.000	56.000	70.000
RESISTANCE TO DEFORMATION	J	5.000	3.000	4.000
STATIC RESISTANCE (CERTIFIED D400)	Kg	40.000		

• = standard equipment

C140G H500		033141212	033140402	033140452
WEIGHT	Kg	70	31	37
C140G H700		033141214	033140404	033140454
WEIGHT	Kg	81	39	44